

Considerations for the Assessment of Chlorinated Solvents

Stephen Druschel, Ph.D., PE
Nobis Engineering
for

Nancy E. Kinner
University of New Hampshire

Characterizing Chlorinated Solvents
September 11, 2007



Questions

- **During Talk Is OK!**
- **Also Time for Questions at End of Talk**
- **Questions Before Break As I have to Go Back to UNH at 11:00am**



Topics Covered

- **Properties of Chlorinated Solvents**
- **Fate in Environment**
 - **Sorption, Dissolution**
 - **Transport**
 - **Reactions**
- **DNAPL Issues**



Overarching Considerations and Questions

- **Porous (Unconsolidated) Media and Fractured Rock**
- **Why Do Chlorinated Solvents End Up Where They Are?**
- **Why Are Chlorinated Solvents So Persistent?**
- **No Vadose Zone or Vapor Issues Covered Today**



Chlorinated Solvents

- **Course Focus = Chlorinated Aliphatic Hydrocarbons (CAHs)**
 - **PCE, TCE, DCE, VC, chloroform, methylene chloride**
 - **Most used as solvents**
 - **No aromatic ring structures**
 - **Rarely 100% pure solvent**
 - **e.g., PCE often has 5% TCE**
 - **Waste mixtures are not pure either**



Exhibit 2-1: CAHs Commonly Identified as Environmental Contaminants

Name	Common Name(s)	Abbreviation ¹	Common Waste Sources
CHLORINATED ETHENES			
Tetrachloroethene(-ethylene)	<i>Perchloroethene</i>	PCE	Solvent waste
<i>Trichloroethene(-ethylene)</i>	None	TCE	Solvent waste, degradation product of PCE
<i>cis-1,2-Dichloroethene(-ethylene)</i>	Acetylene dichloride	cis-DCE	Solvent waste, degradation product of PCE and TCE
<i>trans-1,2-Dichloroethene(-ethylene)</i>	Acetylene dichloride	trans-DCE	Solvent waste, degradation product of PCE and TCE
<i>1,1-Dichloroethene(-ethylene)</i>	Vinylidene chloride	1,1-DCE	Solvent waste, degradation product of 1,1,1-TCA
Chloroethene(-ethylene)	<i>Vinyl chloride</i>	VC	Polyvinyl chloride production waste, degradation product of PCE and 1,1,1-TCA
CHLORINATED ETHANES			
<i>1,1,1-Trichloroethane</i>	Methyl chloroform	1,1,1-TCA	Solvent waste
<i>1,1,2-Trichloroethane</i>	Vinyl trichloride	1,1,2-TCA	Solvent waste
<i>1,2-Dichloroethane</i>	Ethylene chloride	1,2-DCA	Solvent waste, degradation product of 1,1,2-TCA
<i>1,1-Dichloroethane</i>	Ethylidene chloride	1,1-DCA	Degradation product of 1,1,1-TCA
<i>Chloroethane</i>	None	CA	Refrigerant waste, tetraethyl lead manufacturing waste, degradation product of 1,1,1-TCA and 1,1,2-TCA
CHLORINATED METHANES			
Tetrachloromethane	<i>Carbon tetrachloride</i>	CT	Solvent waste, fire extinguisher waste
Trichloromethane	<i>Chloroform, methane trichloride</i>	CF	Solvent waste, anesthetic waste, waste degradation product of CT
Dichloromethane	<i>Methylene chloride, methylene dichloride</i>	MC	Solvent waste, degradation product of CT
<i>Chloromethane</i>	Methyl chloride, monochloromethane	CM	Refrigerant waste, degradation product of CT

Notes:

¹Abbreviations are based on the names in bold italic type.
Sources: Sawyer and others 1994; Merck 1989



Exhibit 2-2: Molecular Structures of Common CAHs

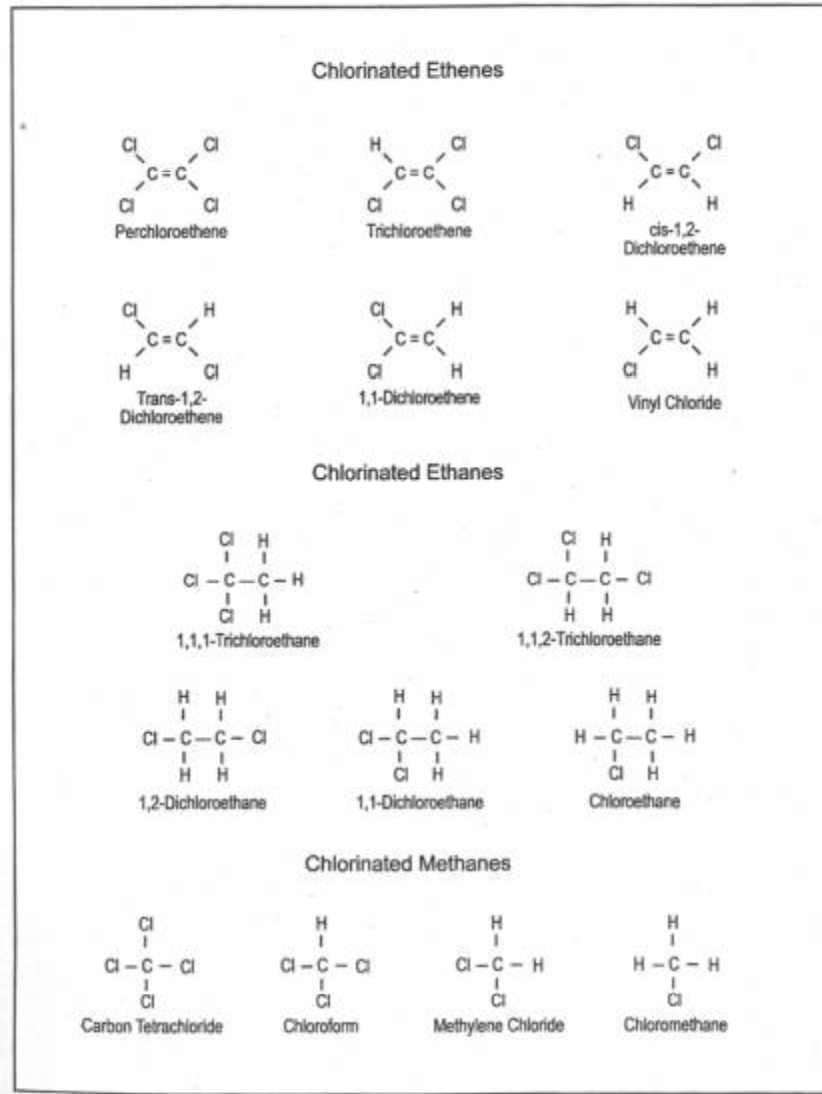

Source: Modified from Sawyer and others 1994



Effects of Chlorine Substitution Into Aliphatic Structure

- **MW ↑, Density ↑**
 - **CAHs are sinkers (Dense NonAqueous Phase Liquids, DNAPLS)**
- **Vapor Pressure ↓, Aqueous Solubility ↓**
 - **High ug/L to low mg/L range**
- **Chlorines Are Electrophilic**
 - **CAHs rarely donate e⁻ and H⁺**
 - **Key difference vs. petroleum hydrocarbons**
- **CAHs Tend to End Up in the Lower Regions of Saturated Zone**
 - **Often in bedrock zone**
 - **At bottom of permeable media (pooling of DNAPL)**



Fate and Transport of Chlorinated Solvents



DNAPLs

- **Hard to Access if in a Pool of Immiscible Fluid**
- **Surfactants May Not Help Biodegradation as They Often Do Not Cause Dissolution of Compound**
 - Only mobilize them as colloidal, non-aqueous phases
- **DNAPL Issues Have Been Subject of Recent ITRC Committees**
 - Last talk today
 - e.g., Bioremediation of DNAPLs



Availability

- **To Be Degraded, Contaminant Must Be Available for Remediation**
 - **Microbes**
 - **Chemical/Physical oxidizing agent**
- **Less Available If:**
 - **Sorbed (adhered) to surfaces**
 - **In non-aqueous phase (DNAPL pool)**
- **For CAHs Low Concentration (ug/L to mg/L) in Aqueous Phase as Dissolved Species**
- **Less Dissolved = Harder to Remediate**
 - **Many remediation agents tend work best on dissolved species**



Sorption

- **Function of Contaminant and the Type of Medium**
 - Clay vs. sand
 - THF vs. TCE
- **Rate of Desorption May Control Degradation Rate**
- **Sorption Has Positive Effect Because Movement to Downgradient Receptors Is Slower**
 - Limits amount of contaminant in solution and being transported with groundwater
 - Contrast of CAHs vs. MtBE which is very soluble and moves rapidly with groundwater



Implications of Sorption and Low Solubility: Minimum Substrate Concentration (S_{\min}) for Bioremediation

- Concentration of Energy-Generating Substrate Below Which Microbe Gets Insufficient Energy for Growth
- Implications – If Contaminant Concentration *In Situ* $< S_{\min}$ → No Biodegradation
- Problem Can Be Avoided If:
 - Another energy-generating compound (e.g., glucose) is available in concentration $> S_{\min}$
 - Multiple substrates all at low concentrations, but aggregate $> S_{\min}$



Mass Transfer

- **Movement of Needed Substances (Substrates) to Cells**
- **Movement of Wastes Away From Cells**
- **Cells Can Be on Surfaces (Biofilm) or Floating in Groundwater**
 - **Normally pristine conditions sorbed to surfaces**
 - Expend little energy swimming
 - Substrates flow to them and wastes flow away
 - **When contamination increases, floating cells increase**
 - Less advantage to being attached



Today's "Classification"

- **Open (macro) fractures/pores**
 - mm to cm apertures
 - Minimal sealing
 - Higher (preferential) flows
- **Microfractures/pores**
 - μm to mm apertures
 - Partially sealed with minerals and clays
 - Diffusion dominates movement of contaminants, etc.





Macrofracture (mm to cm)

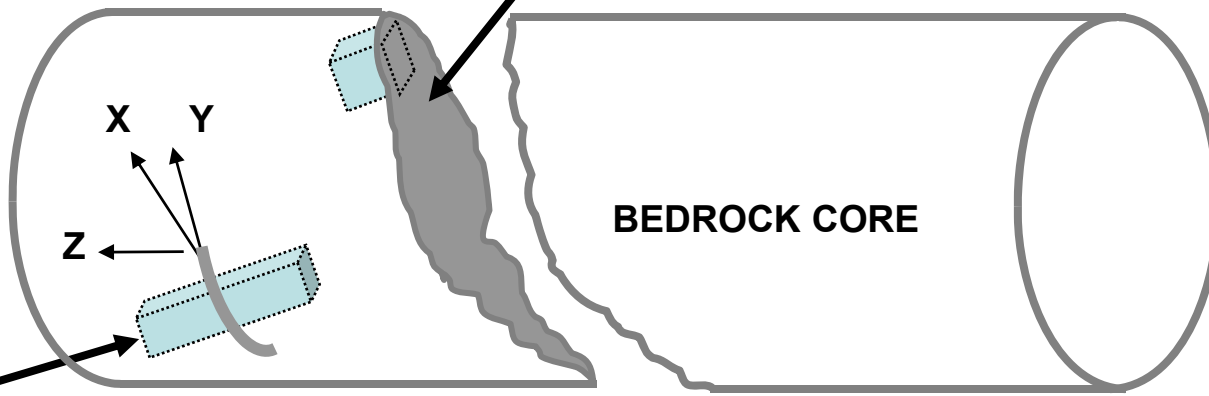

BEDROCK CORE

Microfracture (\leq mm)



Classification for Bedrock

Classification

- **Rock matrix (bulk or host rock) or porous media grain**
- **Weathering rind**
- **Stagnant boundary layer of fluid**
 - **Interface between rock/media surface and fluid**
- **Bulk fluid (porewater)**



Subsurface Conceptual Model

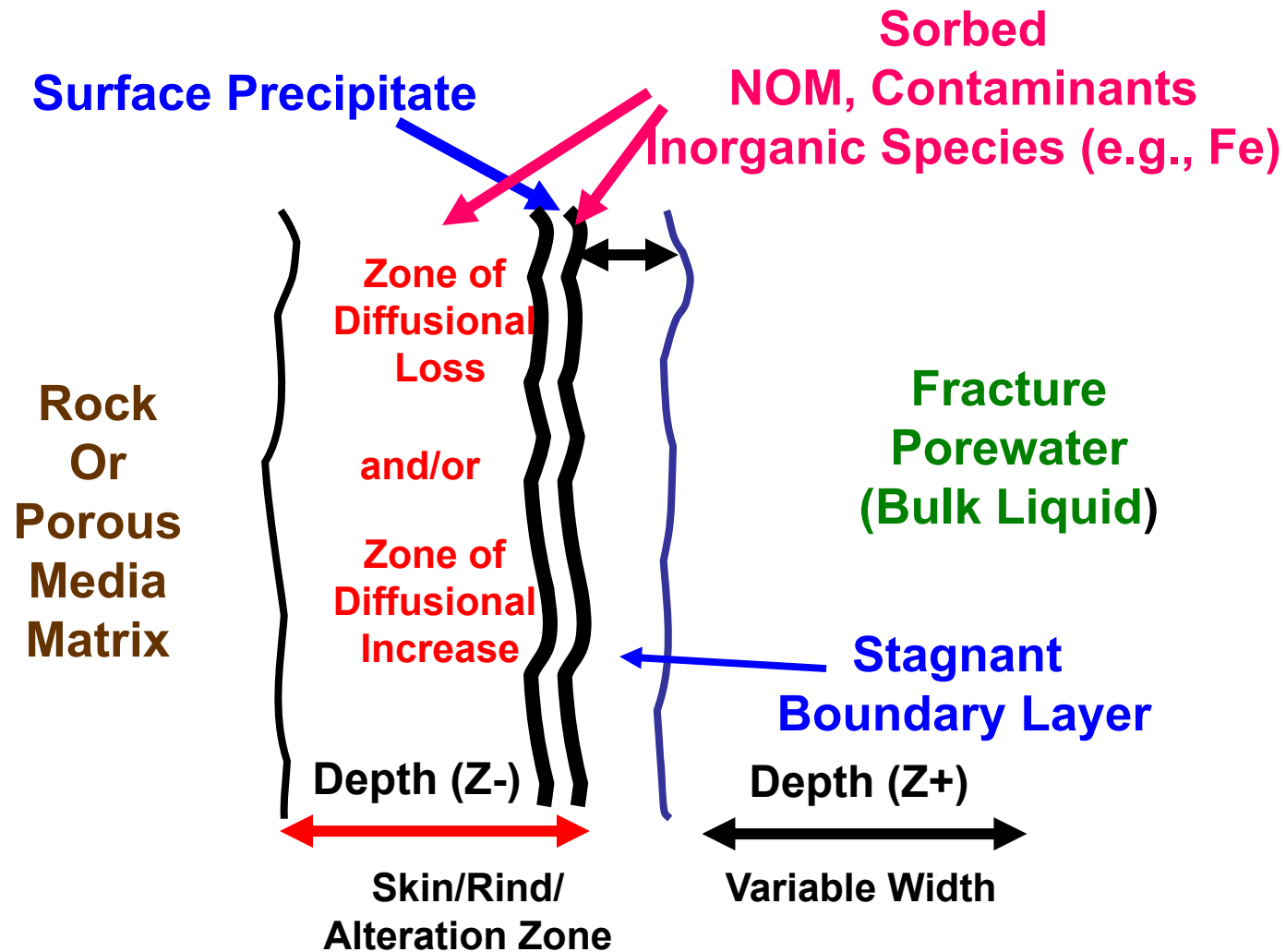

Microfractures/Pores vs. Open Fractures/Pores

- Microfractures/pores often hydraulically isolated vs. open fractures/pores
- More reducing than groundwater pumped from open fractures/pores
- All fractures/pores can differ over small distances
 - Function of heterogeneity of mineralogy and flow regime



Movements of Solutes Within Fractures/Pores

- Flux (mass transfer) across interface
 - Stagnant boundary layer
 - By molecular diffusion only
 - $N_s = \text{Flux}$
 - $N_s = \frac{K}{L} (S_o - S_i)$
 - $N_s = \text{Flux} = \text{mass transferred} / \text{unit surface area} * \text{time}$ ($\mu\text{g}/\text{cm}^2 * \text{d}$)
 - $K = \text{Mass transfer coefficient}$
 - f (temperature, solute diffusion coefficient, fluid types)
 - Surface area / time (cm^2/time)



Movements of Solutes Within Fractures/Pores

$$N_s = \frac{K}{L} (S_o - S_i)$$

- L = thickness of stagnant boundary layer across which diffusion occurs (cm)
- S_b = concentration of diffusing substance in bulk liquid (mass/volume) (μ g/L)
- S_i = concentration of diffusing substance on other “side” of stagnant boundary layer (mass/volume) (μ g/L)



Factors Controlling Mass Flux

- **K = type of substance, environmental conditions, fluid characteristics**
 - **Molecular size, temperature, fluid viscosity**
- **Flow regime – L – thickness of stagnant layer (Flow \uparrow , L \downarrow), surface roughness**
- **Concentration gradient of ($S_b - S_i$)**
 - **High S_b = highly contaminated zone**
 - **Low S_i usually = biodegradation**



Why Do Chlorinated Solvents End Up Where They Are?

- **At the bottom of aquifers**
 - They are more dense than water, so they sink
- **Sorbed to surfaces of porous media/fractures**
 - They can penetrate into the weathering rind (i.e., the matrix)



Why Are Chlorinated Solvents So Persistent?



Abiotic Degradation of CAHs

- **Hydrolysis, Elimination, Abiotic Reductive Dechlorination**
- **Rates Slow vs. Biodegradation**
 - **Only applicable if plume moves very slowly**



Microbial Conceptual Model: Biodegradation of CAHs

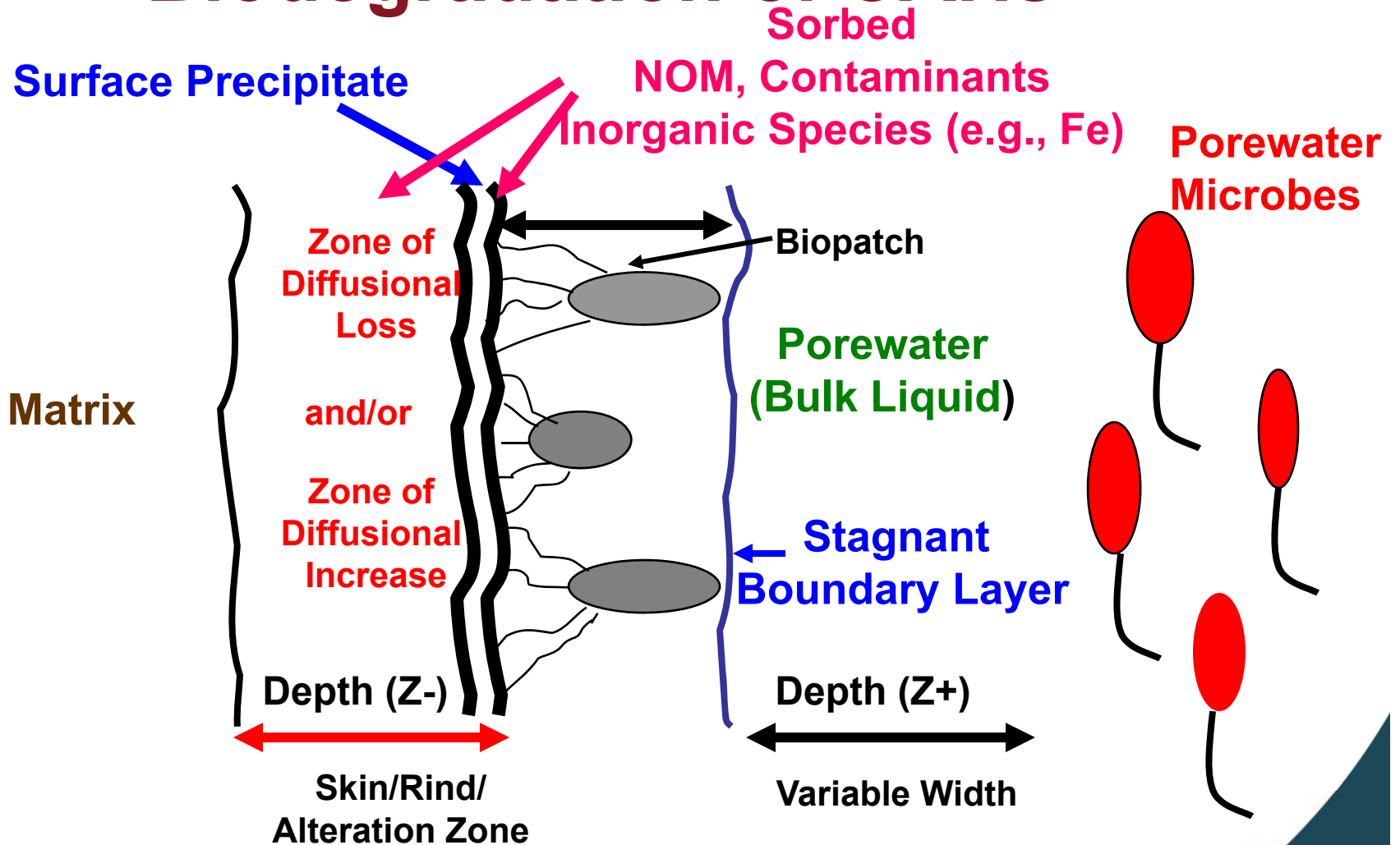

CAH Biodegradation Processes

- **Aerobic Degradation**
 - Direct aerobic oxidation of CAH
 - Co-metabolic oxidation of CAH under aerobic conditions
- **Anaerobic Reductive Dechlorination**
 - Direct anaerobic reductive dechlorination of CAH (Halorespiration)
 - Co-metabolic oxidation of CAH under anaerobic conditions
- **Anaerobic Oxidation of VC and DCE**
- **Many Complex Processes that Will Not Be Considered Today**



CAH vs. Petroleum Hydrocarbon Biodegradation

- CAH Is Much More Confusing
 - CAH often acts as an electron acceptor
- Biological Reactions May Not Convert CAH to CO_2
 - Reactions may stop at intermediates (e.g., VC) which can be worse than original CAH present



CAH Biodegradation Generalizations

- **More Chlorines Per Molecule, Biodegradation More Likely to be Anaerobic Reductive Dechlorination**
 - Carbon atoms in these molecules are highly oxidized because of chlorines
 - So molecules are easily reduced
- **Less Chlorines Per Molecules = Aerobic Degradation**
- **More Chlorines = More Sorption**



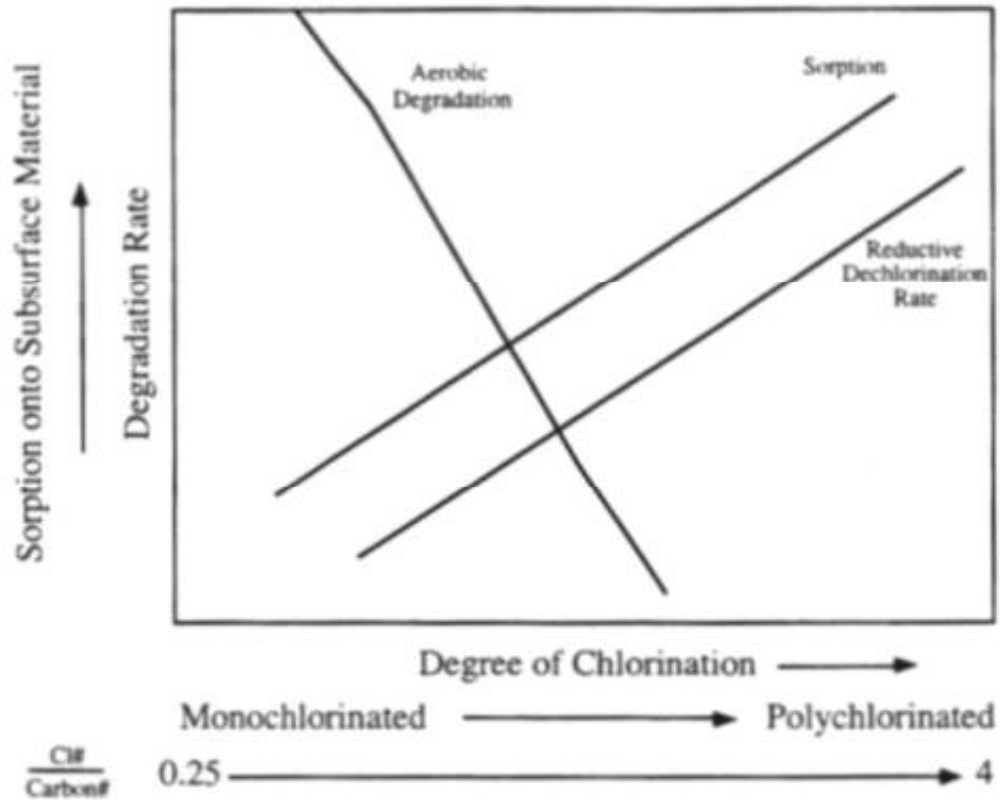

Figure 10.9. Relationships between degree of chlorination and anaerobic reductive dechlorination, aerobic degradation and sorption onto subsurface material.



Norris et.al. p. 10-19 Fig. 10.9 Author of this chapter is [Tim Vogel](#).

Anaerobic Reductive Dechlorination

- **Direct Anaerobic Dechlorination**
 - Also called halorespiration or dehalorespiration
- **Co-metabolic Anaerobic Dechlorination**
- **Results of Both Processes Look the Same**
- **Different Bacteria Perform Them**
- **Need H₂**
 - **Source = fermentation**



Anaerobic Reductive Dechlorination

- Chlorinated Solvents are Electron Acceptors (Oxidizing Agents)
- Reduction Reaction
- Hydrogens Replace Chlorines in Molecule
- Need More Reducing Conditions for VC to Replace Chlorine Than PCE or TCE



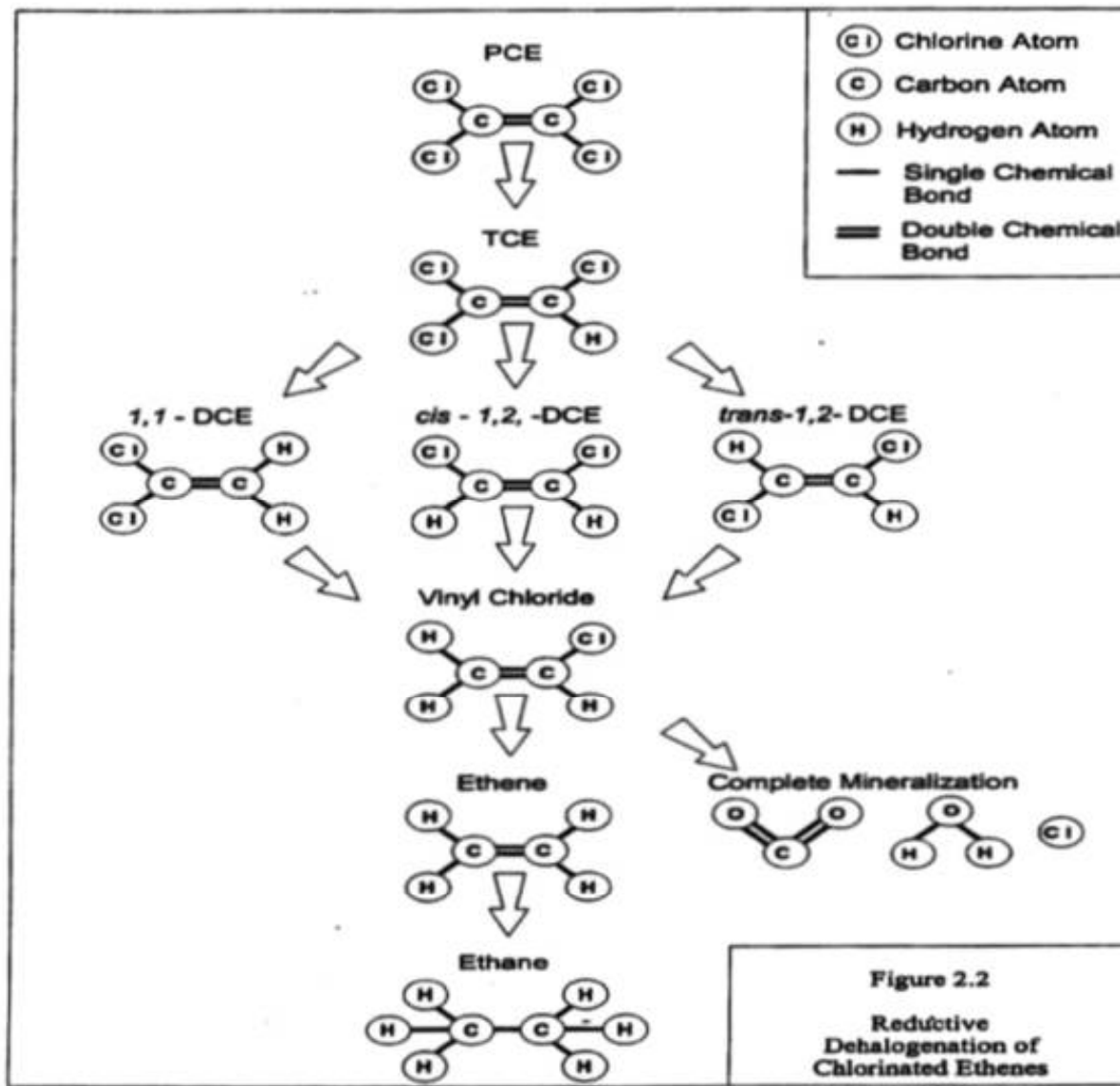

en:chlorinated_protocol/fig2-2.cdr



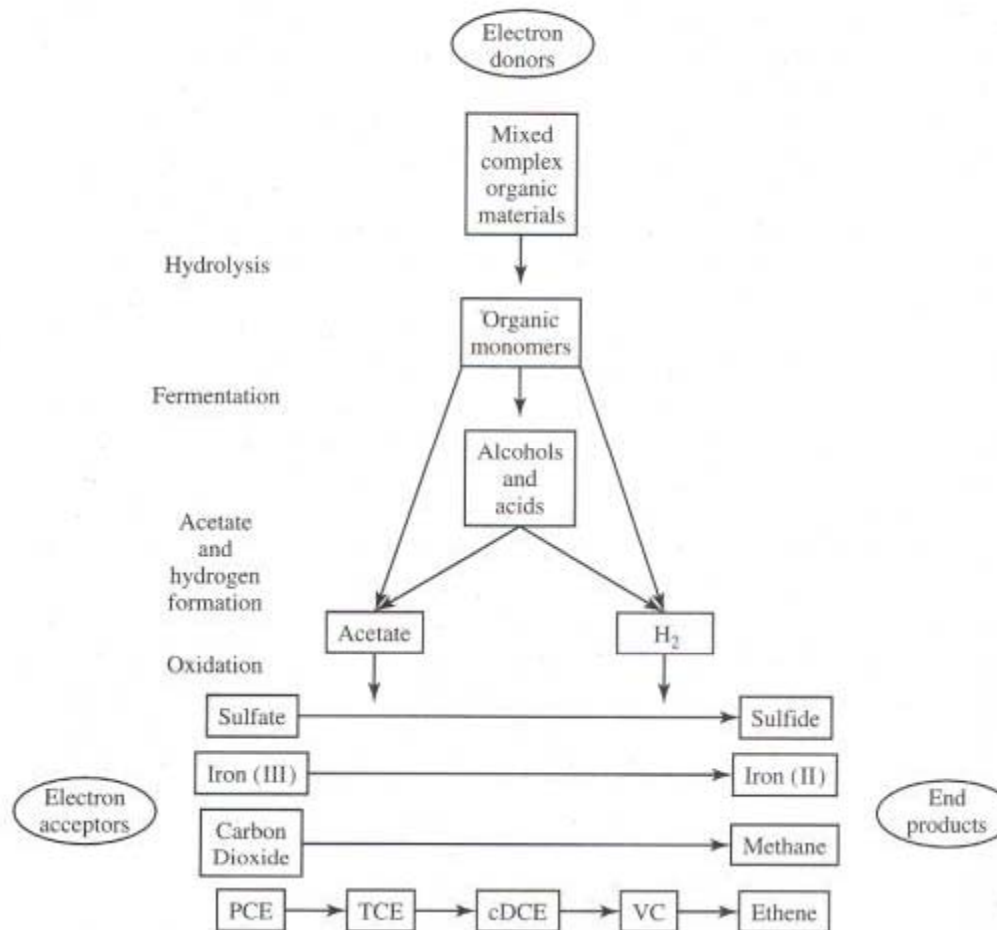

Figure 14.4 Electron flow from electron donors to electron acceptors in the anaerobic oxidation of mixed and complex organic materials. Microorganisms that can use chlorinated compounds (PCE, TCE, cDCE, and VC) as electron acceptors in *dehalorespiration* compete for the electrons in the acetate and hydrogen intermediates with microorganisms that can use sulfate, iron (III), and carbon dioxide. SOURCE: P. L. McCarty, 1997b.



McCarty Figure 3-8

Reduction Hierarchy

PCE	4 Cl	Strongest Oxidizing Agent
TCE	3 Cl	
DCE	2 Cl	
VC	1 Cl	Weakest Oxidizing Agent



Energetics

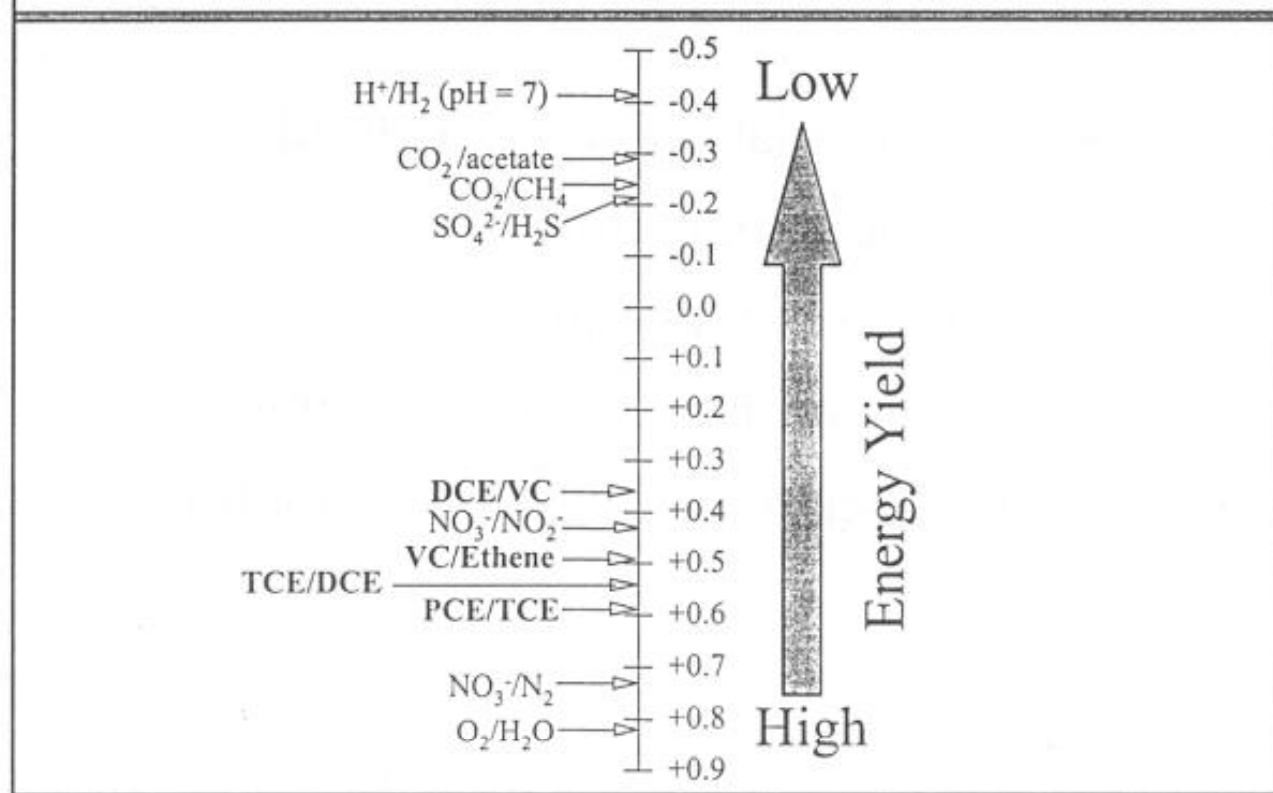

RDTP Workshop.

Energy Generating Processes

- **Energy Generated by Transfer of Electrons (Redox Rxn)**
- **Stored in ATP (Cell's Energy Source)**
- **Need Electron Donor**
 - **Loses e^-**
- **Need Electron Acceptor**
 - **Gains e^-**



Catabolism / Energy Generation

- **Based on:**
 - **Energy source**
 - **Electron donor (redox rxn)**
 - **Carbon requirement**



Basic Respiration: Heterotrophic Bacteria

Organic Carbon + Terminal Electron Acceptor (TEA) → CO₂ + H₂O + Energy

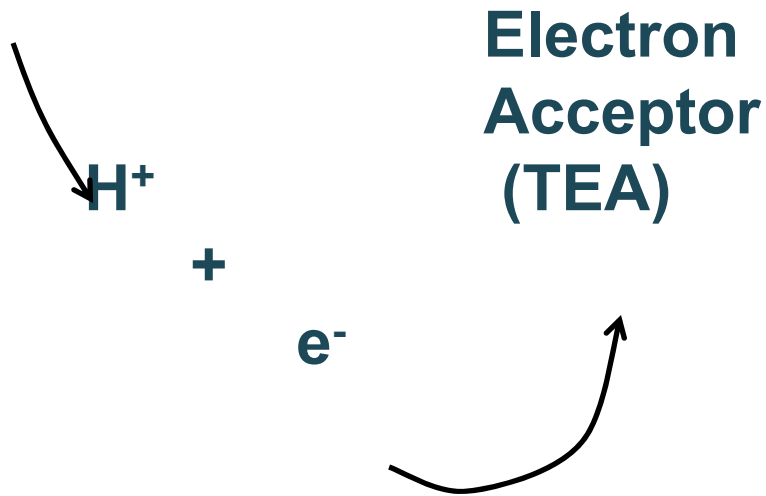

Electron Transport System (ETS)

- **No Organic Molecule Involved**
- **Pass H^+ and e^- Removed from Organic Molecule Down a Chain (ETS)**
 - **Series of oxidation / reduction reactions that generate energy**
- **Need Electron Acceptor at End of Chain (ETS)**
 - **Terminal electron acceptor (TEA)**



Terminal Electron Acceptor (TEA)

- Brought Into Cell
- At End of Electron Transport System
- Accepts Electrons
- Leaves Cells with Electrons



○ = e⁻ and H⁺ carriers

□ = e⁻ carriers only

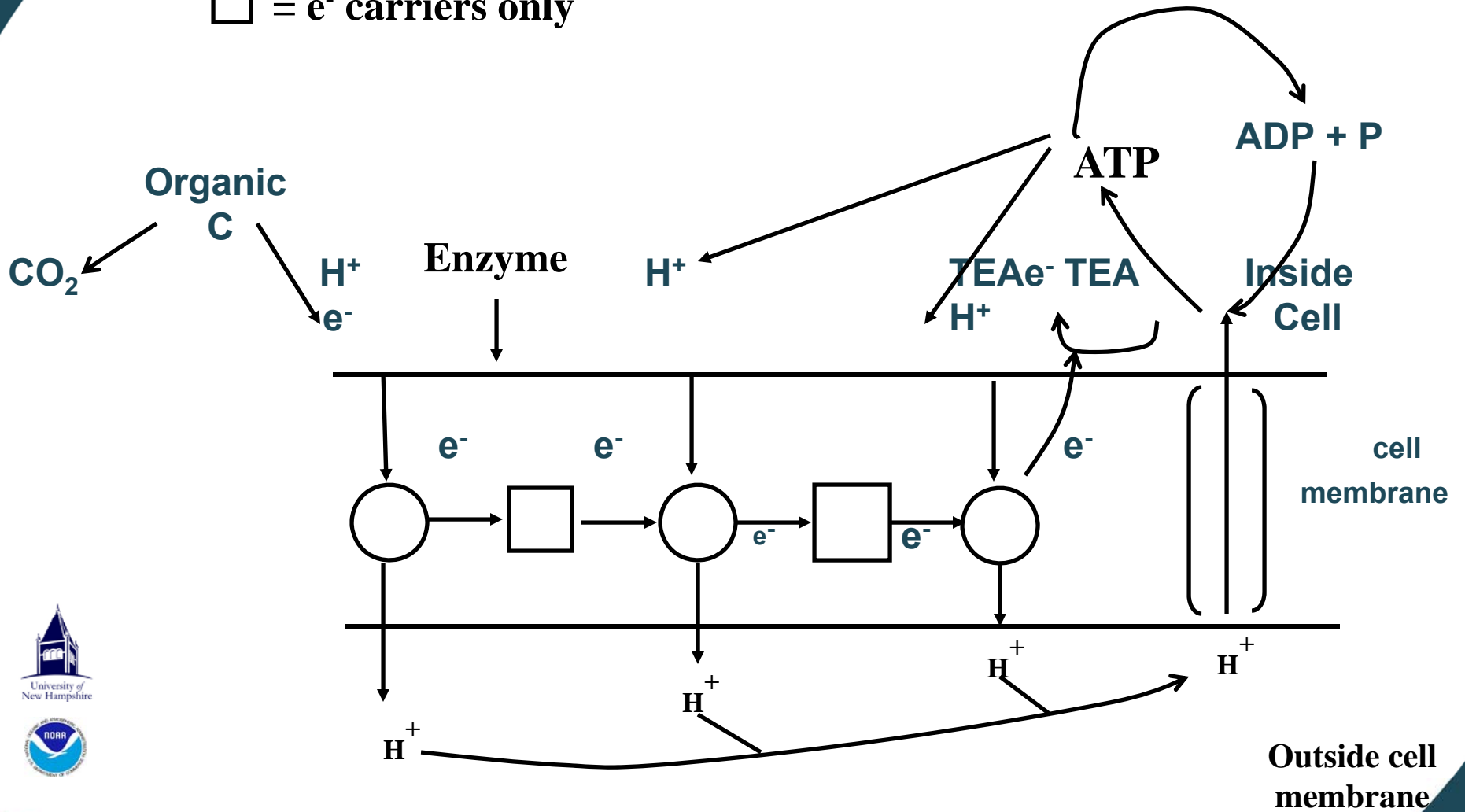

Energetics

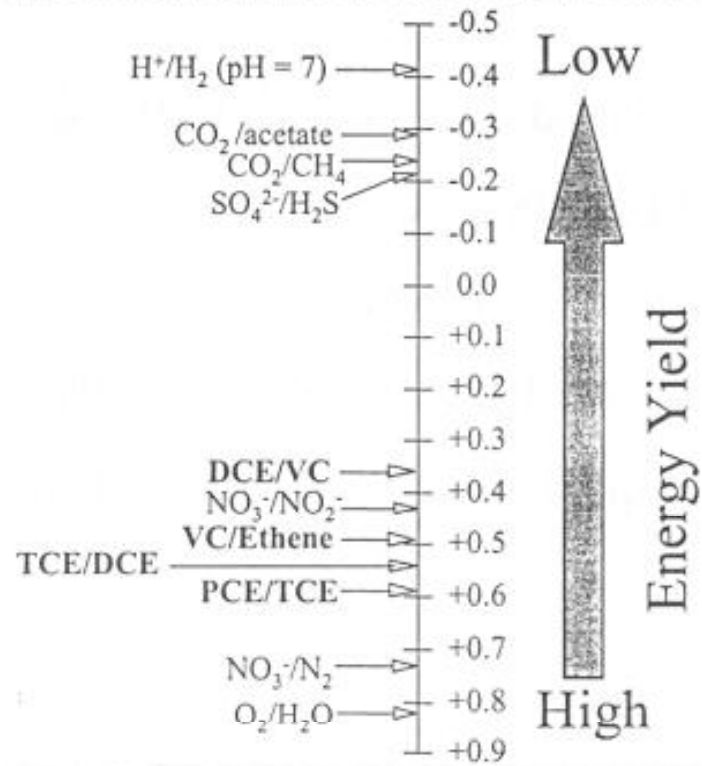

RDTP Workshop.

Energy Generation / Storage

- **When H^+ Is Pushed Outside Cell Membrane Get Gradient**
 - **pH (H^+)**
 - **Electrical (+)**
- **Gradients = Potential Energy**
- **Bring H^+ Back Inside Cell**
 - **Conversion potential \rightarrow kinetic energy**
- **Energy Stored in Higher Energy Phosphate Bonds**



Energy Generation / Storage (cont.)

- $ADP + P \rightarrow ATP \sim PH$
+ H^+
- Release H^+ and Energy When $ATP \rightarrow ADP$
 - Energy used to fuel cell processes



How Far Down ETS Can e⁻ Go?

- e⁻ Can Only be Transferred from One Compound to Another if Receiver Has Higher Affinity for e⁻ Than Donor
 - Gibbs free energy ($\Delta G_0'$ in kJ/e⁻ equiv)
 - If $\Delta G_0'$ is more + (larger) number than species can donate e⁻ to more - (smaller) number

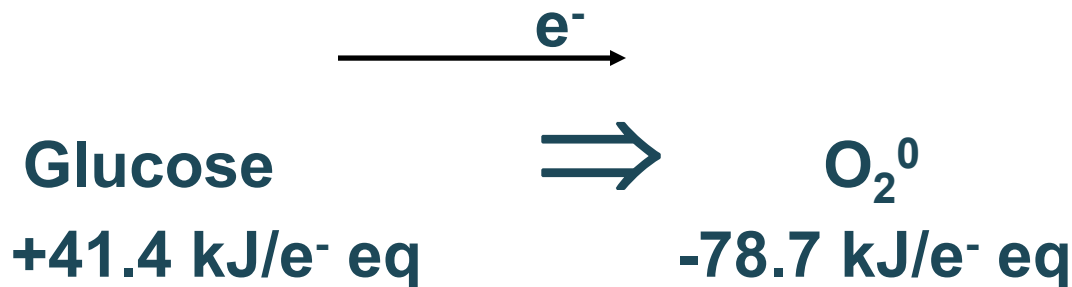

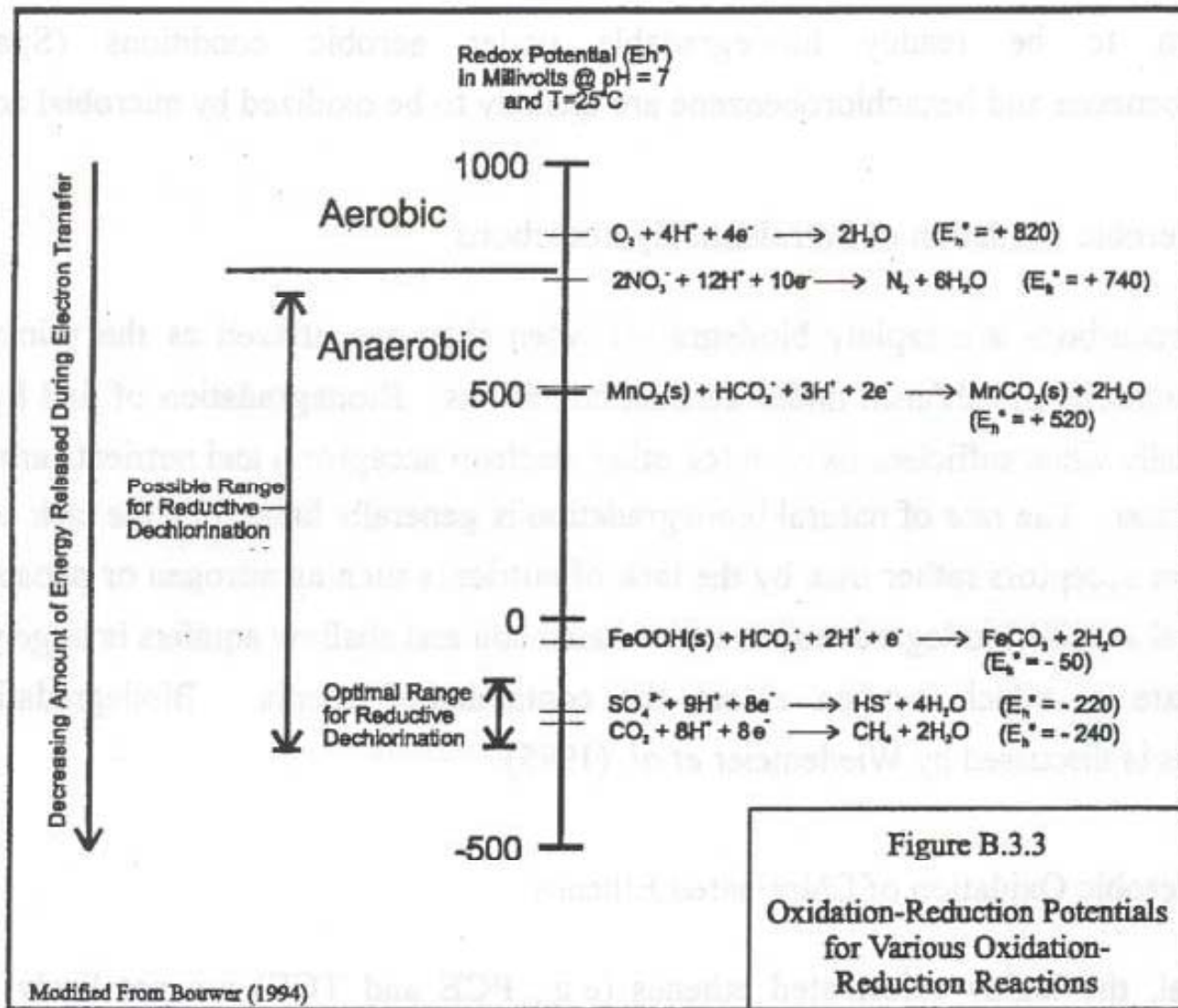

AFCEE, 1996.

Other Factors Affecting Biodegradation

- **Other Substances Cells Need**
- **Abiotic Factors**
- **Interaction Between Substrates**
- **Effects of Other Biological Processes**
- **Bioavailability / Mass Transfer**
- **Recalcitrance**
- **Acclimation**



Interaction Between Substances

- **Little is Known About This**
- **If Multiple Organic Substances Present:**
 - **One may be preferred**
 - Easier to degrade
 - More energy generated
 - Byproducts of one may inhibit other
 - Repression
 - **First may enhance degradation of the second**
 - Byproducts of first may be needed in degradation of second
 - First may induce enzymes needed for second
 - Synergism
 - Co-metabolism



Synergism

- **Multiple Types of Microbes Accomplish Degradation That Neither Can Do Alone**



Co-Metabolism

- **Microbial Transformation of Organic Compound Occurs, But No Energy Gained by Cell**
 - Fortuitous oxidation / metabolism
 - Getting energy and N, P, S etc. elsewhere (from another transformation)
 - C Often Not Incorporated Into Cell Biomass Either



Co-Metabolic Enzymes

- **Enzymes That Catalyze Other Reactions, Catalyze This Co-Metabolic Reaction**
 - **Mostly non-specific enzymes**
 - **e.g., methyl mono-oxygenases that bacteria use to co-metabolize TCE**



Effects of Other Biological Processes

- **Predation – One Organism Eats (Preys Upon) Another**
 - **Predators**
 - Protists
 - Bacteriophage (viruses)
 - **Latest data shows protists affect CAH biodegradation**



Direct Anaerobic Dechlorination (Dehalorespiration)

- Bacteria Present in Many Environments, But Not Ubiquitous
 - e.g., Dehalococcus ethenogenes; Dehalospirillum multivorans



- R-H produced can be ethene, CH₄, CO₂, Less Chlorinated R-Cl
- Need H₂ and Depletion of Competitive Electron Acceptors (e.g., NO₃⁻, SO₄⁻²)



Dehalorespiration

- **Bacteria Gain Energy from this Reduction**
- **Source of H₂ = Fermentation of Organics Occurring in the Environment**
- **Can Sequentially Degrade PCE → TCE → DCE → VC → Ethene**
 - **Most readily for PCE and TCE**
 - **DCE and VC can accumulate**
 - **Presence of PCE can inhibit dehalorespiration of VC**



Impediments to Dehalorespiration

- **Competition for H_2**
 - **Methanogenic bacteria vs. dehalorespirers**
 - **Dehalorespirers can survive at much lower partial pressures of H_2 (i.e., if H_2 production is at slow rate)**
- **If NO_3^- or Sulfate Reduction Occurring May Limit Dehalorespiration**



Enhancement to Dehalorespiration

- **Add Simple Organic Substrates to Spark Fermentation → H₂ Produced**
 - (e.g., amendments = methanol, lactate, benzoate, molasses, vegetable oil, HRC)



Co-Metabolic Reductive Dechlorination

- Methanogens and Sulfate Reducing Bacteria

Main Rxn:



Dissolved
Organic
Matter
(DOM)

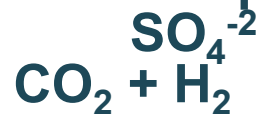

or
H₂S

Co-Metabolic Rxn

R-Cl
PCE
&
TCE
DCE
VC, DCA, CT

Co-metabolic

Rxn R-H + Cl⁻ (No Energy Generated)
may stop here



Anaerobic Reductive Dechlorination Co-Metabolism

- Review Earlier Slides on Co-Metabolism
- Microbial Transformation of Organic Compound Occurs, But No Energy Gained by Cell
- Enzymes That Catalyze Other Reactions, Catalyze This Co-Metabolic Reaction
 - Mostly non-specific enzymes
- Why Does Co-Metabolism Occur?
 - Non-specific enzyme in the microbe converts $A \rightarrow B$, but other specific enzymes in cell cannot degrade B



Anaerobic Oxidation of DCE and VC

- Anaerobic Oxidation of VC and Some DCE → CO₂ Under Fe⁺³ Reducing Conditions
- Anaerobic Oxidation of DCE → VC → CO₂ Under Humic Acid Reducing Conditions
- Also Under SO₄⁻² Reducing and Methanogenic Conditions
- Recent Work by Bradley and Chapelle (USGS-SC)
- Different Pathway
 - Fermentative acetogenic bacteria
 - Generate acetate



Anaerobic Oxidation of VC and DCE (cont.)

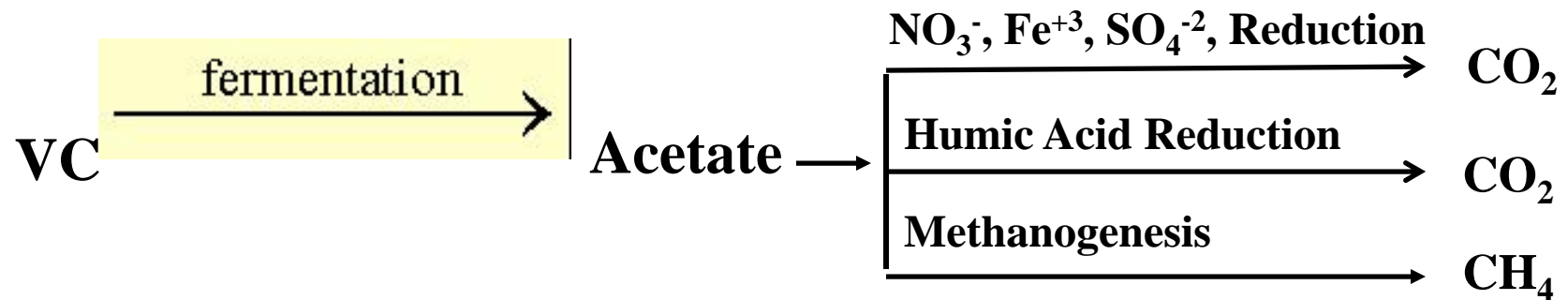

- **Still Unknown How DCE Degradation Works**



Anaerobic Biodegradation

- **PCE → TCE → DCE**
 - PCE and TCE strongest oxidizing agents
 - Occurs under less reducing conditions
 - e.g., nitrate and iron reduction
 - Best under more reducing conditions
- **DCE → VC → Ethene**
 - DCE and VC less strong oxidizing agents
 - Definitely need more reducing conditions (sulfate reducing or best if, methanogenic conditions)
 - Need more hydrogen present



Aerobic Degradation

- **Direct Oxidation of CAHs**
- **Co-Metabolic Oxidations of CAH's Under Aerobic Conditions**



Direct Aerobic Oxidation

- CAH Serves as Carbon and Energy Source (i.e., Electron Donor)

Electron Donor + Electron Acceptor → $\text{Cl}^- + \text{CO}_2$
e.g., VC e.g., O_2 Aerobic +Reduced TEA

- Done by Wide Variety of Bacteria (Ubiquitous)
- More Prevalent for Less Chlorinated VOCs
 - 1 to 2 Chlorines
 - VC, DCE, DCA, Chloromethane, Methylene Chloride



Aerobic Oxidation Co-Metabolism

- Fortuitous Oxidation of CAHs by Bacteria Using Simple Electron Donors
 - CH₄, Propane, Ethene, Butane, Ammonia, Toluene, Phenol
 - No energy gained

Main Rxn Electron Donor + Electron Acceptor → CO₂ + H₂O + Energy
e.g., CH₄ Ethene O₂

Co-metabolic Rxn

R-Cl

Aerobic
co-metabolism

Epoxide Formed



Aerobic Oxidation Co-Metabolism (cont.)

- Enzyme is a Mono-oxygenase
- TCE, DCE, VC, TCA, DCA, Chloroform, Methylene Chloride
- Epoxide Is Unstable
 - Degrades to alcohols and fatty acids
 - Alcohols and fatty acids biodegraded to $\text{CO}_2 + \text{H}_2\text{O}$

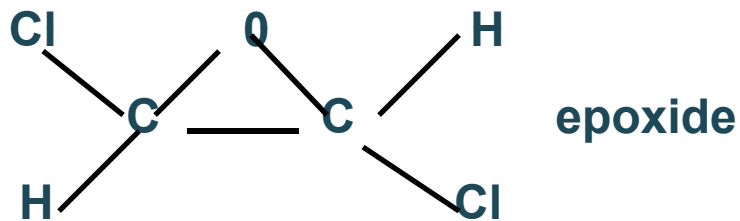

formed from DCE

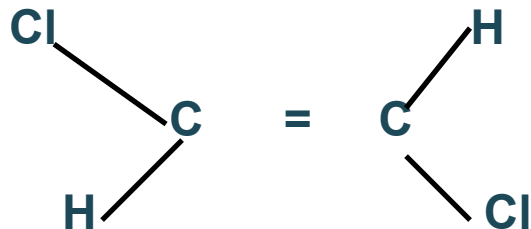

Aerobic Oxidation Co-Metabolism (cont.)

- **Nitrification (Autotrophic Process)**



Co-metabolic
Rxn

R-Cl

Aerobic
co-metabolism

Epoxide

CO₂ + H₂O + Cl⁻

- **Aerobic Co-Metabolism Done by Wide Variety of Bacteria**
 - **Ubiquitous**
 - **Competition Between Primary Substrate (e.g., CH₄) and Co-metabolite for Enzyme**
 - **>1,000:1 Primary Substrate: Chlorinated Solvent Consumed Metabolized**



Aerobic Oxidation Co-Metabolism (cont.)

- **Process Can Be Stimulated by Adding CH₄ and O₂**
 - Alternately, microbes can use toluene or phenol in plume



Combination Anaerobic / Aerobic Processes

- **Anaerobic Reductive Dechlorination Zone (Upgradient)**
PCE → TCE → DCE → VC
- **Direct Aerobic Oxidation Zone (Downgradient)**
VC → Ethene / Ethane → CO₂



Why Are Chlorinated Solvents So Persistent?

**They Are Tough to Degradation
Biologically (“All Stars Must Be Aligned)
and They Are Tough to Degrade Physio-
Chemically (Abiotic Natural Processes
Very Slow; Hard to Get Engineered Agents
Distributed *In Situ*)**



Final Note on CAHs

CAH Monitoring – Units

- **Monitor Parent COC and Progeny**
 - **Not as mg/L**
 - **Use $M = \text{moles/L}$**



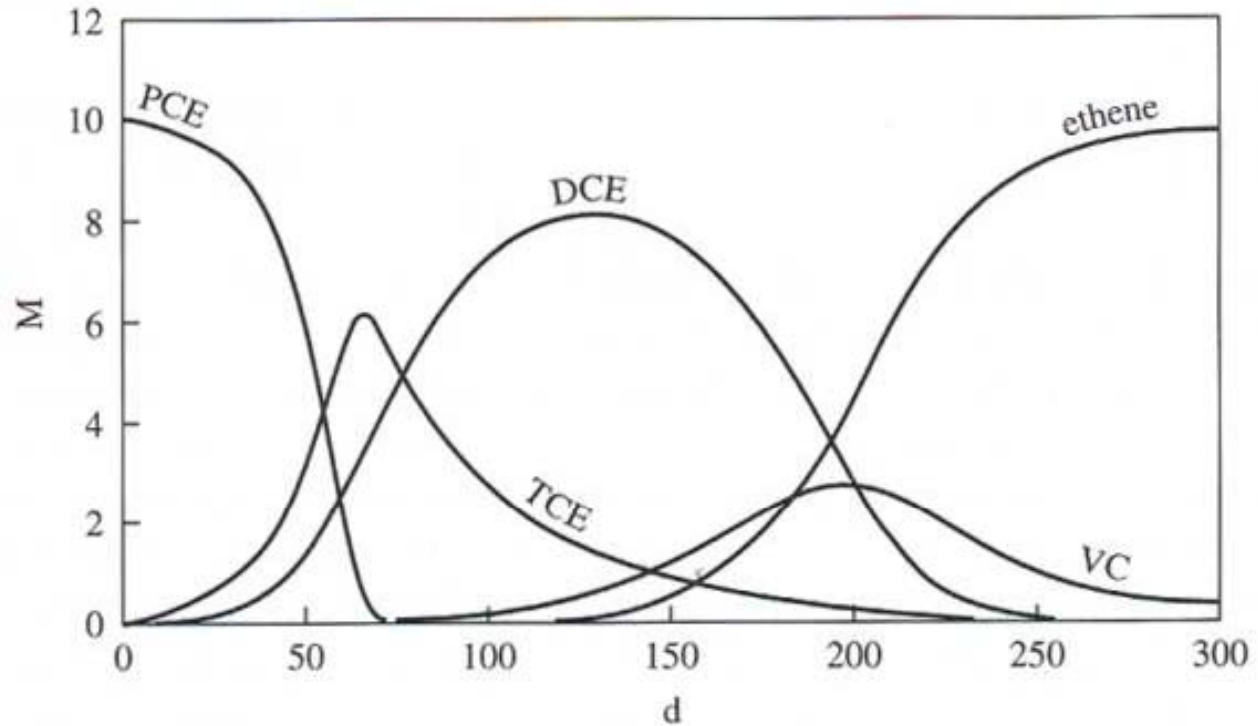

Figure 14.13

Transformation of PCE to ethene by reductive dehalogenation in a batch reactor and assuming two separate microbial populations, one that converts PCE into DCE, and the other, DCE to ethene. The starting concentration of each population is taken as 0.0001 mg/l.



Ritmann and McCarty Fig. 14.13

CAH Stoichiometric Relationships

- For Mass Balance

1 mole PCE → 1 mole TCE → 1 mole DCE → 1 mole VC → 1 mole ethene

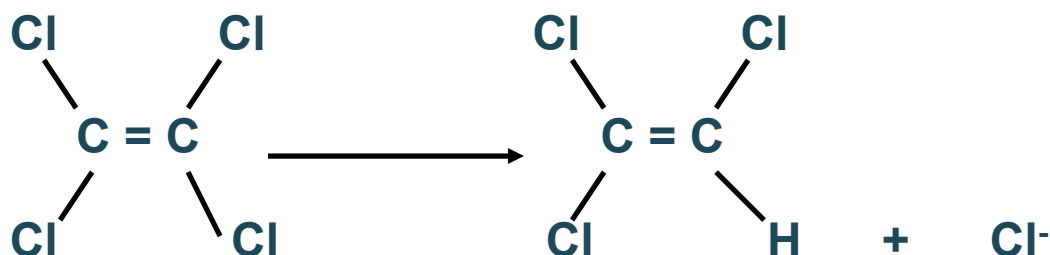

1 mole TCE = 132 g or 1 μ mole TCE = 132×10^{-6} g = 132 μ g
1 mole DCE = 97 g or 1 μ mole DCE = 97×10^{-6} g = 97 μ g
1 mole VC = 62.5 g or 1 μ mole VC = 62.5 μ g VC
1 mole Ethene = 28 g or 1 μ mole Ethene = 28 μ g VC



Conversion of Molar to Concentration

$$1 \mu\text{M} = 1 \frac{\mu\text{mole}}{\text{L}} \text{TCE} \times \frac{132 \mu\text{g TCE}}{1 \mu\text{mole TCE}} = 132 \frac{\mu\text{g}}{\text{L}} \text{TCE}$$

$$1 \frac{\mu\text{mole}}{\text{L DCE}} \times \frac{97 \mu\text{g DCE}}{1 \mu\text{mole DCE}} = 97 \frac{\mu\text{g}}{\text{L}} \text{DCE}$$

$$\text{So } 1 \frac{\mu\text{mole}}{\text{L}} \text{TCE} \longrightarrow 1 \frac{\mu\text{mole}}{\text{L}} \text{DCE}$$



But $132 \frac{\mu\text{g}}{\text{L}} \text{TCE} \neq \frac{132 \mu\text{g}}{\text{L}} \text{DCE} \longleftarrow$ Not $1 \frac{\mu\text{mole}}{\text{L}}$ of DCE

Conversion of Concentration ($\mu\text{g/L}$) to nM

$$\frac{5 \mu\text{g}}{\text{L}} \text{ TCE} \times \frac{\text{nanomole}}{0.132 \mu\text{g TCE}} = 38 \text{ nM} = \frac{38 \text{ nMoles}}{\text{L}}$$

nanomole = 1×10^{-9} moles



**My Deepest Thanks to Steve Druschel
for Covering Today's Talk for Me. I am
Sorry I Could Not Be With You.**

**Contact Info for Further Questions or
Comments:**

Nancy Kinner

nancy.kinner@unh.edu

